

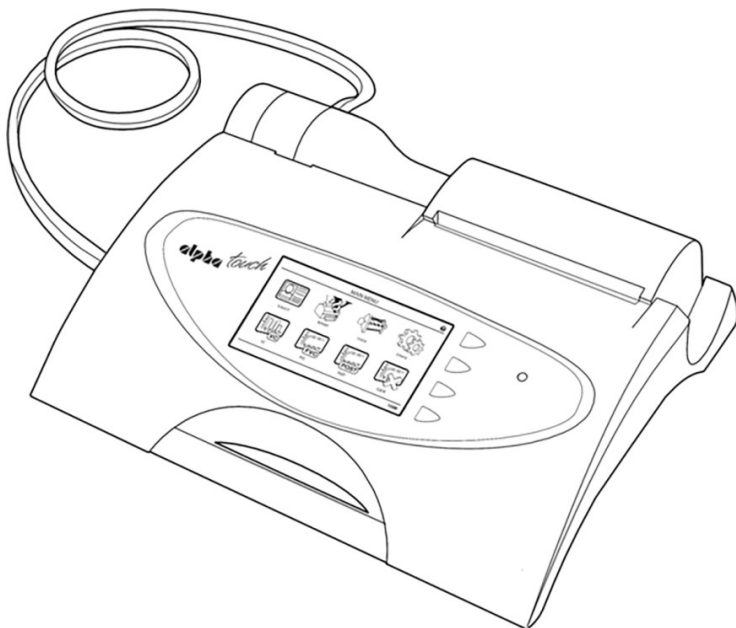

ALPHA Touch

MODEL 6000



Instructions for Use

Vitalograph Branch Addresses

ENG

Vitalograph Ltd, UK

Maids Moreton, Buckingham
MK18 1SW
England

Tel: 01280 827110

Fax: 01280 823302

E-mail: sales@vitalograph.co.uk

www.vitalograph.co.uk

Technical Support

Tel: 01280 827177

Email: tech.support@vitalograph.co.uk

Vitalograph Ltd, International

Maids Moreton, Buckingham
MK18 1SW
England

Tel: +44 1280 827120

Fax: +44 1280 823302

E-mail: sales@vitalograph.co.uk

www.vitalograph.eu

Technical Support

Tel: +353 65 6864111

Email: technical.support@vitalograph.ie

Vitalograph GmbH

Rellinger Straße 64a
D-20257 Hamburg
Germany

Tel: +49 40 547391-40

Fax: +49 40 547391-40

E-mail: info@vitalograph.de

www.vitalograph.de

Technical Support

Telefon: +49 40 547391-14

E-mail: support@vitalograph.de

Vitalograph Inc.

13310 West 99th Street
Lenexa, Kansas, 66215
USA

Toll Free: 800 255 6626

Tel: (913) 730 3200

Fax: (913) 730 3232

E-mail: contact@vitalograph.com

www.vitalograph.com

Technical Support

Tel: (913) 730-3205

Email: technical@vitalograph.com



Vitalograph (Ireland) Ltd

Gort Road Business Park
Ennis, Co Clare, V95 HFT4
Ireland

Tel: +353 65 6864100

Fax: +353 65 6829289

E-mail: sales@vitalograph.ie

www.vitalograph.ie

Technical Support

Tel: +353 65 6864111

Email: technical.support@vitalograph.ie

Vitalograph Ltd, Hong Kong/China

P.O. Box 812
Shatin Central Post Office
Hong Kong

E-mail: sales@vitalograph.cn

www.vitalograph.cn

Technical Support

Tel: +353 65 6864111

Email: technical.support@vitalograph.ie

© Copyright Vitalograph 2019
Current Edition (Issue 1, 26-Nov-2019)
Cat. No. 09100

 is a registered trademark.

Contents

1.	Main Components of the Vitalograph ALPHA Touch	4
1.1.	Features of the Vitalograph ALPHA Touch	5
2.	Setting Up the Vitalograph ALPHA Touch	5
2.1.	Fitting a New Paper Roll	6
3.	Operating Instructions	7
3.1.	Entering Subject Data	7
3.2.	Conducting a Test	7
3.3.	Reporting	11
3.4.	Deleting Stored Subjects/Test Results	11
3.5.	Calibration Verification	12
3.6.	Configuration Options	12
4.	Power Management	19
4.1.	Battery Pack	20
4.2.	Battery Low Detect	20
5.	Cleaning & Hygiene	20
5.1.	Preventing Cross-Contamination of Subjects	20
5.2.	Inspection of the Vitalograph ALPHA Touch	21
6.	Fault Finding Guide	22
6.1.	Software Check	23
7.	Customer Service	24
8.	Consumables and Accessories	24
9.	Disposal	25
10.	Explanation of Symbols	25
11.	Description of the ALPHA Touch	26
11.1.	Indications for Use	26
12.	Technical Specification	26
13.	Contraindications, Warnings, Precautions and Adverse Reactions	28
14.	CE Notice	30
15.	FDA Notice	32
16.	EU Declaration of Conformity	33
17.	Guarantee	34

1. Main Components of the Vitalograph ALPHA Touch

ENG

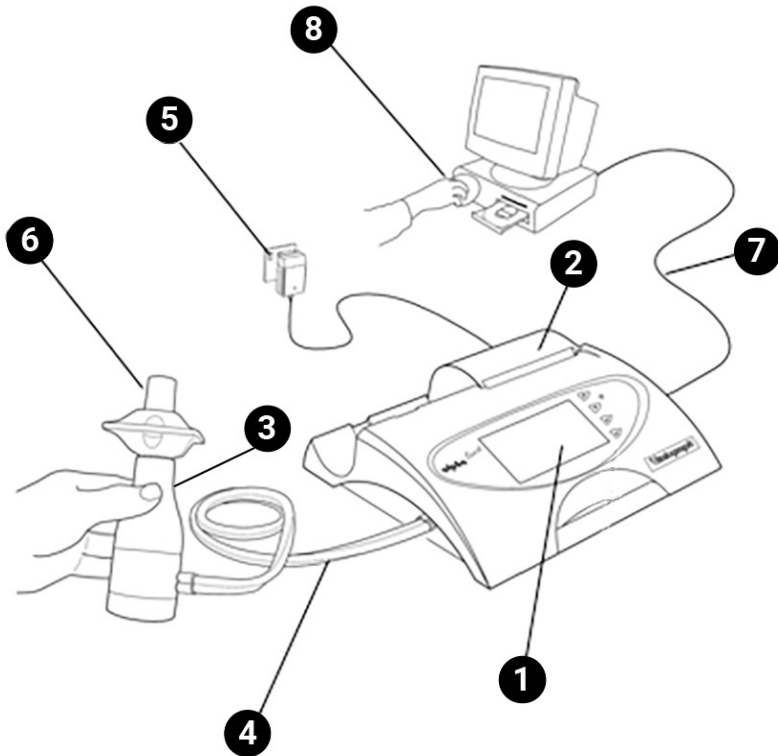

Figure 1 Main components of ALPHA Touch

Note: Computer not supplied

1	Display
2	Internal Thermal Printer
3	Flowhead
4	Flowhead Connection Tubing
5	Medically Approved Power Supply
6	BVF™
7	USB Cable
8	Vitalograph Reports Software (Optional)

1.1. Features of the Vitalograph ALPHA Touch

- Fleisch type pneumotachograph to measure flow
- Ambient temperature sensor
- Touch screen colour display
- Choice of child incentive displays
- Customisable report format
- 10,000 subject test memory
- Diagnostic interpretation options
- Integral printer
- Vitalograph® Reports PC software (included)
- Compatible with Spirotrac software (purchased separately)

2. Setting Up the Vitalograph ALPHA Touch

1. Connect one end of the flowhead connection tubing to the Vitalograph ALPHA™ Touch base. Ensure that the coloured/ribbed tapping on the flowhead is connected to the ribbed side of the tubing in the connector housing.
2. Connect other end of flowhead tubing to the flowhead.
3. Connect the power supply into the rear of the ALPHA Touch. Plug the mains plug into a suitable socket. Switch the ALPHA Touch on (switch at rear) and it is ready for use.

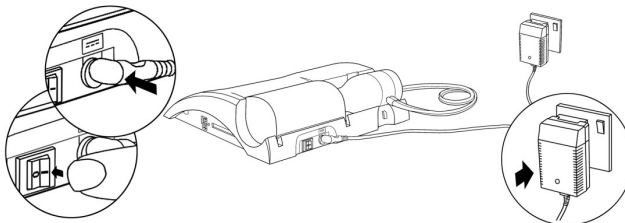



Figure 2: Connecting the power supply and switching on the ALPHA Touch

4. The ALPHA Touch comes fitted with a rechargeable battery pack, which allows the device to be used as a portable device without the mains connected.
5. The ALPHA Touch can print reports directly to its integral printer or send data to a computer for reporting via Vitalograph Reports software (supplied). See section 3.6. Configuration Options for instruction on setting print options.

Note: Only use the ALPHA with the purpose-built low voltage power supply unit with which it is supplied. Attempted use with other power sources may cause irreparable damage and invalidate the warranty.

6. If required, install the Vitalograph Reports software provided with the ALPHA Touch to the computer following the instructions supplied with the

software and connect the ALPHA Touch to the computer using the USB cable (via ports marked with the  symbol).

7. It is also possible to use the Vitalograph ALPHA Touch in conjunction with Spirotrac software (purchased separately). Instructions for using the Vitalograph ALPHA Touch in this way are included in the Spirotrac Instructions for Use.

If the device has just been unpacked or transported, ensure that it is left sitting, fully powered so that it is at room temperature prior to testing.

2.1. Fitting a New Paper Roll

The ALPHA Touch is supplied with a roll of paper fitted into the printer.

Note: Paper is light sensitive so the outside of the roll of paper will not give a strong print impression.

To replace the paper (see Figure 3):

1. Open printer door to expose the head of the printer and the paper cartridge.
2. Take out the cartridge that holds the empty paper roll and remove the empty roll.
3. Put new roll of paper into the paper cartridge and unroll about 12cm (6 inches) of paper.

Note: To make fitting easier, create a point in the middle of the paper by tearing or cutting the two corners of the leading edge of the paper.

Note: The Vitalograph logo should be facing you on the right edge of the paper.

4. Clip the paper cartridge back into place between the back of the ALPHA and the inside of the open door. The paper should come out from the bottom of the roll and point towards the printer. This allows more access to the printer feed mechanism.
5. In the home screen, lift the green lever on the printer.
6. Feed the leading edge of the paper into the bottom slot of the printer until the paper appears through the top of the printer. The paper can now be pulled through. To feed the paper through the printer, press the Enter key on the keypad. This will feed a short length of paper through the printer.
7. Close the green lever.
8. Hold the paper over the paper tear bar and close the door.

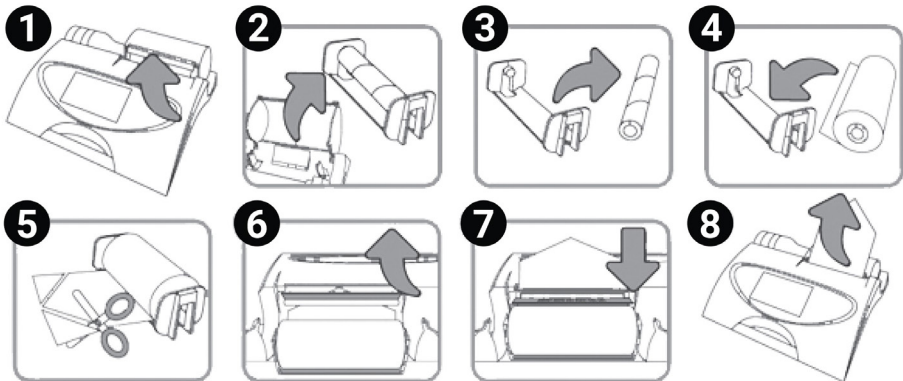

Figure 3 – Fitting a new paper roll.

Warning: The paper tear bar has sharp edges. Take care not to cut fingers.

3. Operating Instructions

Turn on the ALPHA Touch (The On/Off switch is at the back of the device).

3.1. Entering Subject Data

When the device is turned on, the Main Menu screen is displayed.

1. Select a subject by tapping the 'Subject' button onscreen.
2. List the subjects saved on the device by selecting either the Name or ID tab.
3. View the subject details by tapping the subject onscreen. This will select the subject from the database. Select Enter to make this the current subject.
4. To create a new subject, select the New tab. Touch the required field onscreen to highlight, then enter the subject details using the touch panel keypad. Press the 'Enter' button to save the subject to the database and return to the Home Menu.

Note: The current subject surname and forename will be displayed on the bottom left hand corner of the screen.

- If the subject name is not entered then the subject ID will be displayed.
- If the subject has test session results associated with it then the subject name and ID will appear in black.
- If there are no test session results then the subject name and ID will appear in grey.

3.2. Conducting a Test

Before starting a test session:

1. Ensure that the accuracy of the device was checked recently. (Refer to section on Checking Accuracy).

2. Select a subject and ensure the required demographic information is entered.
3. Wash hands (operator and subject).
4. Fit a new Bacterial Viral Filter (BVF) to the flowhead for each test subject. The use of a disposable noseclip is recommended.
5. Instruct and demonstrate the test.

3.2.1. Testing¹

1. Select either 'VC Test' or 'FVC Test' option from the Main Menu.
2. Select how the results should be presented:
 - VC Test – Select from Volume/Time (V/T) graph and Volume (Bar Chart).
 - FVC Test – Select from Volume/Time (V/T) graph and Flow/Volume (F/V) graph.
3. Wait for the 'Exhale to Begin' icon to appear. The device is now ready to accept a blow.

Example script:

- Sit upright, fit the nose clip and relax.
- Place BVF in mouth and close lips around the mouthpiece.
- Seal your lips around the mouthpiece and keep your tongue down.
- Breathe normally.

VC test session

- a. Inhale completely with a brief pause when your lungs are completely full (≤ 2 secs).
- b. Exhale with no hesitation until no more air can be expelled while maintaining an upright posture. It is vital that the operator encourages the subject to keep exhaling to ensure all air is expelled (when a plateau has been reached or forced expiratory time (FET) reaches 15 seconds). The operator should repeat instructions as necessary, coaching vigorously.
- c. Breathe in with maximal effort until completely full. The manoeuvre is now complete and the BVF is removed from the mouth.
- d. Listen for two beeps. The device is now ready for the next blow.
- e. Repeat for a minimum of three manoeuvres, usually no more than eight for adults.
- f. Check VC repeatability and perform more manoeuvres as necessary.



Note: A single-breath VC technique may also be performed on the device.

¹ Derived from terminology and guidance taken from ATS/ERS Standardisation of Spirometry 2019 Update Am J Respir Crit Care Med 2019 Vol 200, Iss 8 pp e70-e88

FVC test session:

- a. Inhale completely and rapidly with a brief pause when your lungs are completely full (≤ 2 secs).
- b. Exhale with maximal effort until no more air can be expelled while maintaining an upright posture. It is vital that the operator encourages the subject to keep exhaling to ensure all air is expelled (when a plateau has been reached or forced expiratory time (FET) reaches 15 seconds). The operator should repeat instructions as necessary, coaching vigorously.
- c. Breathe in with maximal effort until completely full. The manoeuvre is now complete and the BVF is removed from the mouth.
- d. Listen for two beeps. The device is now ready for the next blow.
- e. Repeat for a minimum of three manoeuvres, usually no more than eight for adults.
- f. Check FEV_1 and FVC repeatability and perform more manoeuvres as necessary.

Note: A single-breath FVC technique may also be performed on the device.

3.2.2. Saving the Test Session

The test session is saved to the database by default, by following the on-screen messages.

Note: If a compact flash card is inserted into the compact flash card connector at the right side of the device, then all test blows and not just the best three will be saved to the compact flash card. Results are saved as per the format outlined in the *European Respiratory Journal, 2005; 26: Pages 319-338: ATS/ERS Task Force: Standardisation of Lung Function Testing*.

The Post Mode screen also offers the option to save and recall test sessions to and from a permanent storage location on the device. This permanent storage does not get deleted when test sessions are sent to Vitalograph Reports or Spirotrac. To access this option select 'Permanent Storage'.

The Permanent Storage screen gives you four options:

- **Save Test to Permanent Storage:** An information message will state the memory location where the test session will be saved. There are nine permanent memory locations on the Vitalograph ALPHA Touch.
- **Load Test from Permanent Storage:** The list of permanent pre-test sessions will appear. Select the required pre-test session from the list and select enter to bring you into the Post Mode screen.
- **Delete Test from Permanent Storage:** A list of stored pre-test sessions will appear. Select the Test session to delete and press enter. This location will then be marked as 'Empty'.
- **Delete all Tests from Permanent Storage:** A warning message will appear:- 'Do you want to delete all tests stored in permanent storage?'. Select enter to delete all tests.

3.2.3. Bronchodilator Responsiveness Testing

A Bronchodilator Responsiveness Test session can be performed on an FVC test session following the administration of drugs. Post drug delivery performance is measured versus pre delivery.

- To start bronchodilator responsiveness testing select 'Post Mode' from the Main Menu.
- To perform a bronchodilator responsiveness test on the Pre-test Session just performed, select 'Perform Post test on Current Subject'. This will bring up the test screen. The text 'Post Mode' will appear on the graph.
- To perform a bronchodilator responsiveness test on a different subject or Pre-test:
 1. Select 'Select Subject from List'.
 2. A message 'Warning! Current test session will end. Do you want to save the test session?' will appear. Select Yes and the Select Subject screen will appear.
 3. Select the subject for bronchodilator responsiveness testing.
 4. Select the test session from the Select Test Session screen.

Note: The words Pre, VC or FVC or a combination of these will appear after the session ID.

- If the word Pre appears then a bronchodilator responsiveness test session has already been performed on this pre session.
 - If the word VC appears then a VC test has been done as part of the pre-session.
 - If the word FVC appears then an FVC test has been performed as part of the pre-session.
5. Press 'Enter' to open the test screen. The text Post Mode will appear on the graph.
 6. Perform an FVC test post drug delivery as outlined in section 3.2.1. Testing, to assess bronchodilator responsiveness.

3.2.4. Deleting a Test Session

To delete the current session:

1. Select the 'Clear' option from the Main Menu.
2. A message will appear 'Warning! Current Test Session Will End. Do you want to save the test session?'
 - Select 'Yes' to save the current test session and return to the Main Menu.
 - Select 'No' to clear the current test session and return to the Main Menu.
 - Select 'C' to cancel the operation and continue with the current test session.

3.3. Reporting

Select 'Print' from the FVC Test screen to print the current test session. Refer to section titled 'Report Options' to configure reports.

To produce a report for the Current Subject via the Report option in the ALPHA Touch Main Menu, the following options are available:

- **Current Session:** Select the print icon at the top of the session results screen.
- **Saved Test Session for Current Subject:** Select the required session then the print icon at the top of the session results screen.
- **All Test Sessions:** It is possible to select to print all test sessions for the current subject via a PC using Vitalograph Reports software. It is not possible to automatically print all test sessions for a subject from the internal printer.

To print Test Session(s) from a different subject in the database. Click the 'Select' tab in the View and Report screen. The following options are available:

- **Select Test Session:** Select a subject from the database, and then select a test session for that subject. To print the selected session, select the print icon at the top of the session results screen.
- **All Test Sessions:** It is possible to select to print all test sessions for a selected subject via a PC using Vitalograph Reports software. It is not possible to automatically print all test sessions from the internal printer. Select a subject from the database to use this option.
- **All Test Sessions Between...:** This will print all sessions stored on the device between specified dates via a PC using Vitalograph Reports software. It is not possible to automatically print all test sessions from the internal printer. Select the required date range to use this option.

The default test parameters on the report will vary according to regional requirements. Test parameters can be configured to suit individual requirements. Refer to section on Parameters.

Note: *The internal (thermal) printout will fade over time when exposed to light or heat. If a permanent record is required, photocopy the thermal printout or send the report to the Vitalograph Reports Utility. Refer to section 3.6. Configuration Options for information on selecting the internal or Vitalograph Reports Option.*

3.4. Deleting Stored Subjects/Test Results

Instructions on deleting subjects/test results that have been stored permanently on the device may be found in section 3.2.2. Saving the Test Session.

Instructions on deleting sessions from the device database may be found in section 3.6.2. Database

3.5. Calibration Verification

- Attach flowhead to the syringe with a BVF fitted as per figure 4.

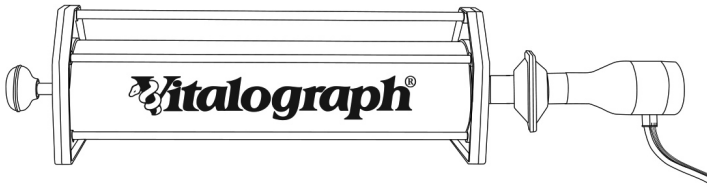

Figure 4: Verifying Calibration

- Select 'Accuracy Check' from the Main Menu using the keypad.
- Enter the Syringe volume and reference using the touch panel keypad.
- Depending on how the device is configured, follow prompts to enter the ambient temperature, humidity (0-99%), pressure (25-31 inHg or 850-1060 hPa-mbar) and altitude (1-8500m). Enter these values using the touch panel or keypad.
- Pump air through the flowhead to bring it to ambient temperature.
- If the flowhead has very recently been used for testing or has come from a cold environment, its temperature should be equilibrated with ambient by pumping air through it from the syringe several times.
- Press the 'Enter' key to open the Accuracy Check screen and follow the on-screen instructions.
- If an Accuracy Check report is required, select the Report option.
- Press the 'C' key to exit the Accuracy Check screen and return to the Main Menu. The accuracy check will not be logged to the Vitalograph ALPHA Touch memory in this case.

Note: If the device is outside calibration, the user is offered the option to update calibration. Selecting to update calibration repeats the accuracy check routine on the device.

3.6. Configuration Options

There are a number of Configuration options available on the Vitalograph ALPHA Touch device. To access these, select the 'Configuration' option on the Main Menu. The options available are:

3.6.1. Test Preferences

The following options are available to configure the test screen to your requirements:

- **FVC Display:** Select to show F/V (Flow-Volume) or V/T (Volume-Time) Graph by default in the FVC test screen. Select the required option from the drop down menu.
- **VC Display:** Select to show the Bar Graph or V/T (Volume-Time) Graph by default in the VC test screen.

- **Test Acceptance:** Select whether to manually accept the tests performed, or allow the device to determine test acceptability (automatic).
- **Graph Scale:** Select the default graph scale.
- **Posture:** Select from 'no posture selected', 'standing' or 'sitting'.
- **Post VC Test:** Selecting 'off' here means that selecting Post testing brings the user directly to the FVC test screen. Post VC testing is 'on' by default where VC testing has been done in a pre-test session.
- **Temperature:** By selecting 'on' in the drop down list, the user is offered the option to manually enter the ambient temperature as they go into the VC or FVC test screens.

3.6.2. Database

To manage the available memory on the device, the Management tab tells you how much subject and test session memory has been used up.

- **Defragment:** Device memory may become fragmented through long use. To maximise available memory, select the defragment option. Defragmentation may take several minutes to complete.
- **Deletion:** To delete a session, select the relevant box. The session will be deleted from the device after being printed. (Either print to an internal printer or sent to Vitalograph Reports). It is also possible to 'Select Test Session(s)' for deletion, or 'Delete Subject(s)' from the device by pressing the relevant button using the touch panel LCD.

3.6.3. Calibration

The Vitalograph ALPHA Touch should never be outside accuracy limits unless damaged or in a fault condition. In this event, see the fault-finding guide. In normal use, calibration traceability certification is recommended as a part of the routine annual service.

The Calibration Options menu contains the following:

- **Calibration:** To calibrate the device
- **Precision Syringe:** To select the volume of syringe used for calibration
- **Linearity:** To check linearity
- **Accuracy Log:** To view and print the accuracy log

Calibration

Calibration is not required for normal use. Calibration should only be conducted by, or under the guidance of Vitalograph Service Agents. See contact details on p. 2.

1. Select 'Calibration' from the Calibration screen.
2. Pump air through the flowhead to bring it to ambient temperature. If the flowhead has very recently been used for testing or has come from a cold environment, its temperature should be equilibrated with ambient by pumping air through it from the syringe several times.

3. Press the 'Enter' key to bring you into the Calibration screen and follow the on-screen instructions.
4. If a Calibration report is required select the Report option.

Press the 'C' key to exit the Calibration screen.

Note: An Accuracy check must be done on the same day as the device is calibrated.

Precision Syringe

1. Select 'Precision Syringe' from the Calibration screen.
2. Select the volume of the calibrated syringe from the drop down list.
3. Enter the syringe reference number using the touch panel keypad.
4. Press Enter to save the new volume entered and return to the Calibration screen. Press C to cancel the changes made and return to the Calibration screen.

Linearity Check

1. Select 'Linearity' from the Calibration screen. (Note: Pressing the C key will exit the Linearity Check screen.)
2. Using a 3L calibrated syringe, pump air through the flowhead to bring it to ambient temperature.
3. If the flowhead has very recently been used for testing or has come from a cold environment, its temperature should be equilibrated with ambient by pumping air.
4. Enter environmental data if prompted to do so.
5. Press Enter to open the Linearity Check screen.
6. Pump air into the flowhead at a slow rate of < 2L/s. Immediately withdraw the syringe at a slow rate. This manoeuvre should show on the graph between the two red lines. If it is a correct manoeuvre the table on the screen will show 'Test 1', and the FVC and FIVC values will be updated. Repeat for the slow rate three times.
7. Repeat the procedure for a medium rate >2L/s and < 6L/s. This manoeuvre should show on the graph between the red and green lines. If it is a correct manoeuvre the test number and the FVC and FIVC values will be updated in the table. Repeat for the medium rate three times.
8. Repeat the procedure for a fast rate >6L/s. This manoeuvre should show on the graph between the outside green lines. If it is a correct manoeuvre the test number and the FVC and FIVC values will be updated in the table. Repeat for the fast rate three times.
9. When all the manoeuvres are complete press Enter for the result.
10. If a Linearity Check report is required select the 'Report' option.

Accuracy Log

1. Select 'Accuracy Log' from the Calibration screen. The accuracy log contains a record of all the accuracy checks done on the device.
2. There are three options:
 - a. To print the complete accuracy log press 'Print All'.
 - b. To print a log of the last 30 accuracy tests done, press 'Print Last 30'.
 - c. To view the accuracy log, press 'View'.
3. Press C to return to the Calibration screen.

3.6.4. Settings

The following options are available in the Device Settings screen:

- **Date/Time:** Update the date and time including format
- **Units:** Metric/Imperial
- **Sound Options:** On/Off/Volume
- **Power Save Options:** Display dulls after 3 minutes
- **Incentive:** Select incentive, % predicted and % best test
- **Parameters:** Select parameters for report/printing

Date/Time

There are two tabs in this screen for the time and date.

1. Change the time by scrolling the hours and minutes to the required settings by pressing the arrows on the touch panel LCD.
2. Change the time format from 24 hour to 12 hour by switching the '24 Hour Format' option off or on.
3. Change the date by scrolling the day, month and year to the required settings by pressing the arrows on the touch panel LCD.

Units

Modify the units by selecting between Metric and US (Imperial) in the drop down list.

Sound Options

- Select Off/On options for Key, Flow, Error and Welcome sounds on the device.
- Adjust the volume by pressing the '-/+ ' on the touch panel LCD.

Power Save Options

In order to improve battery life the device can be configured to dull the display after 3 minutes. This can be switched on or off.

Incentive

The Incentive Device is used as an aid in testing of children.

1. Select the incentive device to be used in testing using the drop down list. A preview of the incentive will appear on the screen.
2. Modify the % of predicted using the on-screen keyboard. The value entered must be between 80-150.
3. Modify the % of Best Test value using the on-screen keyboard. The value entered must be between 80-150.

Parameters

The following parameters can be reported and printed for a test session. To select/unselect a parameter check/uncheck the relevant check boxes. Additional parameters are available by selecting the additional index tabs.

Parameter	Definition
VC	Vital capacity (L)
IVC	Inspiratory vital capacity (L)
FIVC	Forced inspiratory vital capacity (L)
FVC	Forced vital capacity (L)
FEV.5	Forced expiratory volume after 0.5 seconds (L)
FEV.75	Forced expiratory volume after 0.75 seconds (L)
FEV1	Forced expiratory volume after 1 second (L)
FEV3	Forced expiratory volume after 3 seconds (L)
FEV6	Forced expiratory volume after 6 seconds (L)
PEF L/s	Peak expiratory flow (L/sec)
PEF L/min	Peak expiratory flow (L/min)
FEF0.2-1.2 (F02-12)	Mean forced expiratory flow in the volume interval between 0.2 and 1.2 L of the test (L/sec)
FEF 25-75 (F2575)	Maximal mid expiratory flow: the mean FEF in the time interval between 25% and 75% of the FVC (L/sec)
FEF 75-85 (F7585)	Forced late expiratory flow: the mean FEF in the time interval between 75% and 85% of the FVC (L/sec)
FEF 25	Forced expiratory flow at 25% of the FVC (L/sec)
FEF 50	Forced expiratory flow at 50% of the FVC (L/sec)
FEF 75	Forced expiratory flow at 75% of the FVC (L/sec)
FIV1	Forced inspiratory volume after 1 second (L)
PIF L/s	Peak inspiratory flow (L/sec)

FIF 25	Forced inspiratory flow at 25% of the FVC (L/sec)
FIF 50	Forced inspiratory flow at 50% of the FVC (L/sec)
FIF 75	Forced inspiratory flow at 75% of the FVC (L/sec)
MVVind	Maximum voluntary ventilation indirectly calculated from the FEV1 (L/min)
FMFT	Forced mid-expiratory flow time (sec)
FET	Forced expiratory time (sec)
Vext	Extrapolated volume (L)
FRC	Functional residual capacity (L)
TV	Tidal volume (L)
RV	Residual volume (L)
TLC	Total lung capacity (L)
IRV	Inspiratory reserve volume (L)
ERV	Expiratory reserve volume (L)
IC	Inspiratory capacity (L)
Rind	Airways Resistance Indirect measurement.
FIVC/FVC	Ratio FIVC of FVC
FEV.5/FVC	Ratio FEV 0.5 of FVC
FEV1/FEV6	Ratio FEV1 of FEV6
FEV1/FVC	Ratio FEV1 of FVC
FEV1/VC	Ratio FEV1 of VC
FEV1/PEF	FEV1 divided by PEF (L/L/s)
FEV3/VC	Ratio FEV3 of VC
FEV3/FVC	Ratio FEV3 of FVC
FEF 25-75/FVC F2575/F)	Ratio FEF 25–75 of FVC
FIV1/FVC	Ratio FIV1 of FVC
FIV1/FIVC	Ratio FIV1 of FIVC
FIF50FEF50	Ratio FIF 50% of FEF 50%
FEV75/FVC	Ratio FEV 0.75 of FVC
FEV1/FIVC	Ratio FEV1 of FIVC
FEV1/IVC	Ratio FEV1 of IVC
FEV1R	FEV1 divided by the largest VC from the VC or FVC manoeuvre.

Vext/FVC	Ratio extrapolated volume of FVC
PIF L/min	Peak inspiratory flow (L/min)
Lung Age	Lung age will be displayed if the date of birth, height, population group and smoking information have been entered. Lung age will only be shown if the measured FEV1 value is less than the lower limit of the predicted normal value for FEV1.

3.6.5. Subject Options

The following options are available in the Subject Options screen:

- **Primary View:** Set the default subject list view to either name or ID using the drop down list.
- **Password protection:** Select to turn password protection on/off. Change the password using the touch panel keypad.
- **Smoking History, Population Group and Weight:** Select whether to include these fields when creating a new subject on the device. To change the setting select the on/off button on the touch panel keypad.

3.6.6. Smart Options

Configure the device to follow a set sequence of operation on power up using the Smart Options. Turn Smart Options Off/On using the drop down menu. When turned on there are four areas that may be configured by selecting from a drop down list:

- **After Power Up:** Configure the device to go to the Main Menu or the Subject screen after power up.
- **After Subject:** Configure the device to go to VC Test, FVC Test or Main Menu after selecting a subject.
- **After VC:** Configure the device to go to FVC or Main Menu after performing a VC test.
- **After FVC:** Configure the device to go to POST mode, Print the test or go to the Main Menu after performing an FVC test.

3.6.7. Report Options

Set the Report Content and the Report Method using the Report Options screen.

Report Content

The following information printed on the session reports may be configured by selecting from a drop down list:

- **Table:** Configure the device to show the results for the best test only (Best 1) or the three best tests (Best 3).
- **Normal Comparison:** Configure the device to print either the % of

- Predicted value or the SDS (Standard Deviation Score) in the session table of results.
- **Test QA:** Configure the session report to show the test QA. Select to turn this on or off.
 - **Interpretation:** Configure the session report to show the device suggested interpretation. Select to turn this on or off.
 - **Comments Header:** Configure the session report to show a Comments Header. Select to turn this on or off.
 - **Ambient Conditions:** Configure the session report to show the Ambient Conditions. The ambient conditions (Humidity, Pressure and Altitude) are those entered when performing an accuracy check or calibration update. Select to turn this on or off.
 - **V/T Size:** Configure the Volume/Time graph displayed to either standard or ATS/ERS 2005 (ATS) requirements.
 - **F/V Size:** Configure the Flow/Volume graph to either standard or ATS/ERS 2005 (ATS) requirements.
 - **V/T Graph:** Configure the session report to show the V/T (Volume vs. Time) graph. Select to turn this on or off.
 - **F/V Graph:** Configure the session report to show the F/V (Flow vs. Volume) graph. Select to turn this on or off.
 - **Trend Graph:** Configure the session report to show the trend graph. Select to turn this on or off. The trend graph can only be printed when the trend graph option and the configurable report option are selected.

Report Method

The ALPHA Touch can print to the internal printer or Vitalograph Reports. The following options are available:

- **Report:** Select either 'Send to PC' or 'Internal Printer' from the drop down list.
- **Content:** Select 'Default report' or the 'Configurable report' option from the drop down list.
- **Colour:** The printout can be set to Colour or Black & White. Select on for a colour printout (print via a PC) and off for black & white.

Note: In order to send the report to the Vitalograph Reports utility it is necessary to have the Vitalograph Reports Utility installed on the user's PC and the ALPHA Touch connected to the PC via a USB cable.

4. Power Management

The Vitalograph ALPHA Touch can be powered using the 12V low voltage power supply unit with which it is supplied or from the internal battery pack. When powered from the low voltage power supply, the LED on the front face on the device will be green. When the device is powered from the battery pack,

the LED will be orange. The Power Supply unit should be checked regularly and replaced when necessary.

ENG

4.1. Battery Pack



The ALPHA Touch is fitted with a rechargeable Battery Pack. This allows the device to be used without the 12V Power Supply connected. The battery pack can be re-charged by plugging in the 12 V Power Supply. To fully re-charge switch off the Vitalograph ALPHA Touch and leave it plugged in over-night.

The battery pack should be replaced after 3 years. Battery replacement should be carried out only by the manufacturer, the approved importer or by Service Agents specifically approved by Vitalograph.

Note: *It is not possible to power the device or charge the batteries from the USB.*

4.2. Battery Low Detect

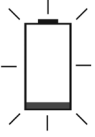
The battery power detect messages are:

	<p>Battery Low: The icon flashes on and off on the Main Menu screen. The Battery Pack is running low. You may continue to use the device. As a precaution, plug in the 12V Power Supply to re-charge the batteries and continue testing.</p>
	<p>Battery Discharged: The icon appears continuously on the Main Menu screen. The Battery Pack is out of power. If you press any key a warning message appears and you will not be allowed to proceed further. Plug in the 12V Power Supply to re-charge batteries and continue testing.</p>

5. Cleaning & Hygiene

5.1. Preventing Cross-Contamination of Subjects

A spirometer is not designed or supplied as a ‘sterile’ device. Vitalograph intends that a new Bacterial Viral Filter (BVF) be used for every subject to prevent cross contamination. Using a new BVF provides a significant level of protection of for the subject, the device and the user against cross contamination during spirometry manoeuvres.

The interior of a Vitalograph flowhead does not require decontamination where a new BVF is used for each subject. The outside surfaces of the device and flowhead tube may be cleaned with a 70% isopropyl alcohol impregnated cloth to remove any visible soiling and for low level disinfection.

Where the user suspects that the flowhead has become contaminated or where local risk assessment identifies a need for higher level of decontamination, then it should be cleaned as per the instructions on ‘Cleaning and Hygiene’ on the Vitalograph website.

5.2. Inspection of the Vitalograph ALPHA Touch

Visual inspection is recommended on a routine basis; Remove flowhead cone and flowhead end cap from the flowhead (figure 5). Examine flow conditioning mesh filters for damage or contamination. If they are damaged or blocked, discard and replace with new parts. Examine the O-rings on the Fleisch element and replace if damaged. Re-assemble the cone and end cap.

It is recommended that an accuracy check is carried out following cleaning and re-assembly as recommended in the ATS/ERS 2019 guidelines².

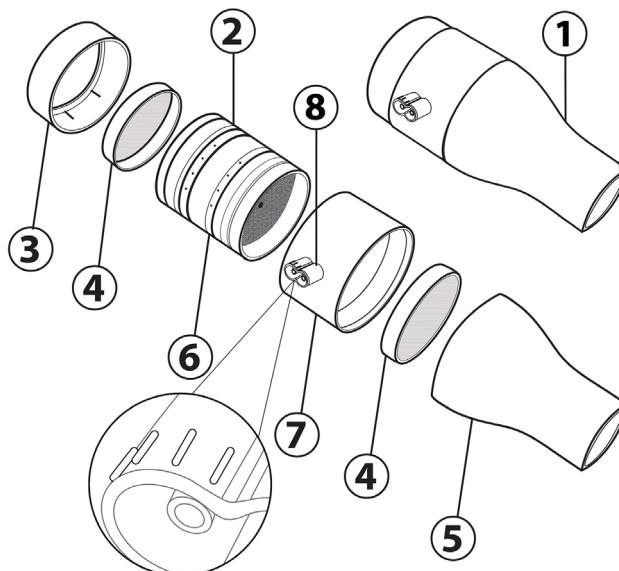

Figure 5: Flowhead Assembly

1	Flowhead Complete
2	'O' Rings
3	Flowhead End Cap
4	Flow Conditioning Meshes
5	Flowhead Cone
6	Fleisch Element
7	Flowhead Body
8	Port Pressure Tappings
	Lubrication: Silicone Grease

² Derived from terminology and guidance taken from ATS/ERS Standardisation of Spirometry 2019 Update Am J Respir Crit Care Med 2019 Vol 200, Iss 8 pp e70-e88

6. Fault Finding Guide

ENG

<p>Problem Fault Symptoms:</p>	<ul style="list-style-type: none"> • Accuracy check variations > +/-3% • False readings suspected.
<p>Possible Solutions: (In probable order)</p>	<ul style="list-style-type: none"> • Recheck Calibration with reference to section Checking Accuracy. • Was the correct syringe volume selected? • An accuracy check is required after cleaning/ disinfecting the flowhead Fleisch element assembly. • Flowhead cone Fleisch element filter mesh missing or blocked. • Flowhead body pressure port holes blocked. • Flowhead Fleisch element assembly sealing 'O' rings damaged. • Flowhead Fleisch element assembly not dried thoroughly. • Flowhead Fleisch element assembly blocked. • Flowhead body tubing from pressure ports to main PCB blocked – contact support. • Main PCB failure – contact support.
<p>Problem Fault Symptoms:</p>	<ul style="list-style-type: none"> • Test begins automatically. • Volume accumulates automatically without the subject blowing. • Very small VC or FVC test displayed.
<p>Possible Solutions: (In probable order)</p>	<ul style="list-style-type: none"> • Flowhead and/or tubing not stationary at the start of test. Hold them steady until the 'Ready to Blow' prompt appears. • Return to Main Menu and re-enter the test routine.
<p>Problem Fault Symptoms:</p>	<ul style="list-style-type: none"> • Rocking device.
<p>Possible Solutions: (In probable order)</p>	<ul style="list-style-type: none"> • Check for damaged or missing rubber feet. • If any of the rubber feet are damaged or missing replace all six rubber feet.
<p>Problem Fault Symptoms:</p>	<ul style="list-style-type: none"> • Reversed or no volume measurements.

Possible Solutions: (In probable order)	<ul style="list-style-type: none"> • Ensure tubing is connected correctly. Ribbed side of the tubing should be connected to the ribbed half of the connector on the Vitalograph ALPHA Touch device and the blue tapping on the flowhead connector. • Ensure that the flowhead connecting tube is not pinched or trapped.
Problem Fault Symptoms:	<ul style="list-style-type: none"> • Cannot print to internal printer.
Possible Solutions: (In probable order)	<ul style="list-style-type: none"> • Check that internal printer is selected in the Configuration screen. • Check the paper is loaded correctly and not reversed. • Ensure the green lever on the printer is pressed down. • Internal printer failure – contact support.
Problem Fault Symptoms:	<ul style="list-style-type: none"> • Cannot print to PC (Vitalograph Reports Utility). • Corrupt or missing data on printout.
Possible Solutions: (In probable order)	<ul style="list-style-type: none"> • Check that external printer is selected in the Configuration screen. • Check USB cable is connected between Vitalograph ALPHA Touch and the PC. • Check to ensure the Vitalograph Reports Utility is correctly installed. • Check to ensure the required software drivers are installed on the PC. • Main PCB failure – contact support.
Problem Fault Symptoms:	<ul style="list-style-type: none"> • Cannot read screen.
Possible Solutions: (In probable order)	<ul style="list-style-type: none"> • Ensure the switch on the back of the unit is in the 'On' position. • LCD failure – contact support. • Main PCB failure – contact support.

6.1. Software Check

The software version and issue can be determined from the About screen. Please quote this, and the serial number of the Vitalograph ALPHA Touch, to an approved manufacturer's support desk when requesting further advice or assistance.

7. Customer Service

Service and repairs should be carried out only by the manufacturer, or by Service Agents approved by Vitalograph. Contact information for approved Vitalograph Service Agents may be found at the start of this manual.

Any serious incident that has occurred in relation to the device should be reported to Vitalograph or its Authorized Representative and the Regulatory Authorities of the country. Refer to the Vitalograph contact information at the start of this manual.

8. Consumables and Accessories











Cat. No	Description
28350	BVF - Bacterial/Viral Filters (50)
28501	Eco BVF – Bacterial/Viral Filters (100)
28572	Eco BVF and Disposable Nose Clip (80)
28554	Eco BVF with Bite Lip (75)
28553	Eco BVF with Bite Lip and Disposable Nose Clip (75)
20303	Nose Clips (200)
36020	3-L Precision Syringe
66149	Thermal Printer Paper (5)
42084	Flow Conditioning Mesh (10)
67252	USB Cable
65054	Alpha 12V PowerSAFE Spare UK
65055	Alpha 12V PowerSAFE Spare EU, AU, US
61030	Flowhead Complete
42029SPR	Flowhead Connection Tube
77939	Flowhead Cone
77938	Flowhead End Cap
2120013	O-Ring (15)
65354	CD with User Manual
65049	Test Data Storage Card
65030SPR	Vitalograph Reports Utility





9. Disposal

The device must be taken to separate collection at the product end-of-life. Do not dispose of these products as unsorted municipal waste.

Used BVFs constitute minimally soiled waste from human healthcare and should be disposed of in line with local requirements. BVFs are made from polypropylene.

10. Explanation of Symbols

Symbol	Description
	Type BF equipment
	Class II
VA	Power rating
	Direct current
	Instructions for Use; operating instructions
	Manufacturer
	Year of Manufacture (Date format YYYY-MM-DD)
	USB connector
	The device must be taken to separate collection at the product end-of-life. Do not dispose of these products as unsorted municipal waste
	Fragile, handle with care
	Keep Dry
	Storage Temperature Limit

	Storage Relative Humidity Limits
	Do not re-use
	Non sterile
	Recycle
	QR code - matrix bar code. All information in the bar code is included in the text under it

11. Description of the ALPHA Touch

The Vitalograph ALPHA Touch is a spirometer which measures subject respiratory parameters including but not limited to VC, FVC, FEV1, PEF and MVV. It is designed for desktop use. The Fleisch flowhead is used for testing and has a resting location on the device.

11.1. Indications for Use

The indications for use of the Vitalograph ALPHA Touch is in the assessment of lung function through the measurement of dynamic lung volumes, i.e. spirometry.

The ALPHA Touch is designed to be operated by medical professionals trained in respiratory and lung function testing on adults and paediatrics, 2.5 years and older, in a variety of professional healthcare environments, e.g. primary care, hospitals and occupational health centres. The measurements obtained from a lung function test provide objective information used in the diagnosis of lung diseases and monitoring lung health.

12. Technical Specification

Product	Vitalograph ALPHA Touch, Model 6000
Flow Detection Principal	Fleisch type pneumotachograph
Volume detection	Flow integration sampling @ 100Hz
Maximum test duration	90 seconds
Maximum displayed volume	10 L

Volume Accuracy	Better than $\pm 3\%$ or $\pm 0.05\text{L}$ of the reading. (ISO 26782:2009)
Flow Measurement Range	Max. flow rate $\pm 960\text{ L/min}$ ($\pm 16\text{ L/s}$) Min. flow rate $\pm 1.2\text{ L/min}$ ($\pm 20\text{ L/s}$)
PEF Accuracy	$\pm 10\%$ or $\pm 10\text{L/min}$ of the reading (ISO 23747:2015)
Back pressure	Less than 0.1kPa/L/sec @ 14L/sec (ATS/ ERS 2019)
Operating temperature range	ISO 26782 limits: $17\text{--}35^\circ\text{C}$ Design limits: $10\text{--}40^\circ\text{C}$
Operating humidity range	$30\%\text{--}75\%$
Ambient pressure range	$850\text{hPa}\text{--}1060\text{hPa}$
Performance standards the Vitalograph ALPHA Touch meets or exceeds	ATS/ERS 2019, ISO 23747:2007 & ISO 26782:2009
Safety standards	EN 60601-1:2006
EMC Standards	EN 60601-1-2:2007
QA/GMP standards	EN ISO 23747:2007, EN ISO 26782:2009 & FDA 21CFR820
Dimensions	300 mm (length) x 250 mm (depth) x 75 mm (height)
Weight	2kg net
Storage Temperature	$0\text{--}50^\circ\text{C}$
Storage Relative Humidity	$10\%\text{--}95\%$
Printer	Thermal
Communications	USB
Power Supply	12V , 1.5A DC power supply 7.2V , 1.8Ahr NiMH battery
Essential Performance	Flow measurement output
Essential Performance Test Limits	Flow Accuracy $\pm 10\%$ or $\pm 20\text{ L/min}$ (ATS/ERS 2005)

<p>Minimum PC System Requirements to run Spirotrac/ Vitalograph Reports Software</p>	<p>Processor Speed: 2GHz or greater RAM: 2GB (Min), 4GB (Recommended) Disk Space: 1GB or greater Operating System: Windows 7 or above Monitor: 1280 x 800 pixel Other: .Net framework 4.5.1 USB Port</p>
<p>Notes:</p> <ul style="list-style-type: none"> • All values displayed are expressed as BTPS values. • Take care not to block the mouthpiece with tongue or teeth. A 'spitting' action or coughing will give false readings. • Time zero is determined using the back-extrapolated method, from the steepest part of the curve. The operating and storage conditions specified apply to the device plus accessories. • The flowhead and BVF are classified as type BF applied parts. The device body or other accessories are not applied parts. • An applied part is a part of the equipment, which in normal use necessarily comes into physical contact with the subject for equipment or system to perform its function. 	

13. Contraindications, Warnings, Precautions and Adverse Reactions

1. No modification of this equipment is allowed. Any unauthorised changes to the Vitalograph ALPHA Touch device may compromise product safety and/or data and as such Vitalograph cannot be held responsible and the device will no longer be supported.
2. The ALPHA Touch is not designed as a sterile device. Always follow the safety guidelines given by the manufacturer of cleaning and disinfectant chemicals.
3. For the device to be used as intended, there is no requirement to clean the supporting computer. If cleaning is required to remove any visible soiling, this should be done as per the computer manufacturer's instructions.
4. Vitalograph intends that a new Bacterial Viral Filter (BVF™) be used for every subject to prevent cross contamination. Using a new BVF provides a significant level of protection of the subject, the device and the user against cross contamination during spirometry manoeuvres. A BVF is for single use only.

5. Spirometry is a valuable tool that provides important information to clinicians which is used together with other physical findings, symptoms, and history to reach a diagnosis (ATS/ERS 2019).
6. When using the ALPHA Touch ensure that the flowhead connecting tube is not pinched or trapped as spirometry results may appear to be inverted.
7. Take care not to block the mouthpiece with tongue or teeth during testing. A 'spitting' action or cough will give false readings.
8. Subject fatigue may occur during spirometry testing depending on the subject's characteristics e.g. age, health status. For safety reasons, testing should be preferably done in the sitting position, using a chair with arms and without wheels. Subject may also take a break between tests.
9. All values displayed are expressed as BTPS values
10. Time zero is determined using the back-extrapolated method, from the steepest part of the curve
11. Do not expose the ALPHA Touch to liquids with the exception of the isopropyl alcohol impregnated cloth specified for cleaning.
12. The ALPHA Touch should not be used in the presence of flammable liquids or gases, dust, sand or any other chemical substances.
13. All spirometry standards recommend checking the accuracy of lung function measuring devices daily with a 3-L syringe to validate that the instrument is measuring accurately. The ALPHA Touch should never be outside accuracy limits. Accuracy should be checked after cleaning or disassembling the spirometer for any reason, after adjusting calibration or if the flowhead or device has been dropped.
14. Service and repairs should be carried out only by the manufacturer or by Service Agents approved by Vitalograph.
15. Maintenance must not be performed while the device is in use by a subject.
16. The device contains a Lithium coin cell battery and a Nickel-metal hydride (NiMH) main battery which are not accessible by the user. Any suspected battery faults should be reported to the manufacturer.
17. The internal NiMH battery is not user accessible or user replaceable. In the unlikely event that any issues are noted with the power or battery such as swelling or leaking, stop using the device immediately, do not charge the device and contact Vitalograph support. In case of leaking ensure the electrolyte does not get in the eyes or touch skin. If electrolyte contacts the eyes flush the area immediately with water for 15 minutes and seek medical attention. If electrolyte contacts the skin wash the affected area immediately and seek medical attention. Do not inhale the leaked material, leave the area immediately and allow the battery to cool and any material to dissipate.
18. Use of accessories and cables other than those specified or provided by Vitalograph for this equipment could result in increased electromagnetic emissions or decreased electromagnetic immunity of the ALPHA Touch and

result in improper operation.

19. Non-medical equipment must be kept outside the subject environment i.e. any area in which intentional or unintentional contact between the subject and parts of the system, or some other persons touching part of the system, can occur.
20. Portable RF communications equipment (including peripherals such as antenna cables and external antennas) should be used no closer than 30 cm (12 inches) to any part of the ALPHA Touch, including cables specified by Vitalograph. Otherwise, degradation of the performance of this equipment could result.
21. Use of this equipment adjacent to or stacked with other equipment should be avoided because it could result in improper operation. If such use is necessary, this equipment and the other equipment should be observed to verify that they are operating normally.
22. The applied part is the Flowhead. This along with the BVF, are the contact points for the subject during a spirometry session. There are no adverse effects if the subject comes into contact with any other part of the ALPHA Touch device.

14. CE Notice

Marking by the symbol  indicates compliance of the Vitalograph Model 6000 ALPHA Touch to the Medical Devices Directive of the European Community.

The Vitalograph Model 6000 ALPHA Touch is intended for use in a variety of professional healthcare environments, e.g. primary care, hospital wards and occupational health centres, except for near active high frequency surgical equipment and the RF shielded room of an ME system for magnetic resonance imaging, where the intensity of electromagnetic disturbance is high. The customer or the user of the ALPHA Touch should assure that it is not used in such an environment.

The Model 6000 ALPHA Touch has been tested in accordance with:

EN60601-1: 2006 - Medical electrical equipment. General requirements for basic safety and essential performance

EN 60601-1-2:2007 Medical electrical equipment - Part 1-2: General requirements for basic safety and essential performance - Collateral Standard: Electromagnetic disturbances - Requirements and tests.

EN 60601-1-2:2007 - Emissions tests		
Emissions test	Compliance	Electromagnetic environment - guidance
RF emissions CISPR 11	Group 1	The Model 6000 ALPHA Touch uses RF energy only for its internal function. Therefore, its RF emissions are very low and are not likely to cause any interference in nearby electronic equipment.
RF emissions CISPR 11	Class B	The Model 6000 ALPHA Touch is suitable for use in all establishments, including domestic establishments and those connected to the public mains network (e.g. at home and doctor's offices in residential areas)
Harmonic emissions IEC 61000-3-2	Class A	
Voltage fluctuations/ flicker emissions IEC 61000-3-3	Class A	

EN 60601-1-2:2007 - Immunity tests		
Immunity test	Test level	Compliance level Reached
Electrostatic discharge (ESD) IEC 61000-4-2	±6 kV contact ±8 kV air	±6 kV contact ±8 kV air
Electrical fast transient/burst IEC 61000-4-4	±2 kV for power supply lines ±1 kV for input/ output lines	±2 kV for power supply lines
Surge IEC 61000-4-5	±1kV differential mode ±2kV common mode	±1 kV differential mode

Voltage dips, short interruptions and voltage variations on power supply input lines IEC 61000-4-11	<5% 100V (>95% dip in 100V) for 0,5 cycle	Performance A
	40 % 100V (60% dip in 100V) for 5 cycles	Performance A
	70 % 100V (30% dip in 100V) for 25 cycles	Performance A
	<5% 100V (>95% dip in 100V) for 5 sec	Performance A
Conducted RF IEC61000-4-6	3 Vrms 150kHz to 80 MHz in ISM bands	3 Vrms 150kHz to 80 MHz in ISM bands
Radiated RF EN 61000-4-3	3 V/m 80MHz to 2700MHz	3 V/m 80MHz to 2700 MHz
Warning: In the unlikely event of an electrostatic discharge causing the ALPHA Touch to switch off, the device should be turned off and then on again using the power switch.		

Medical Devices may be affected by mobile RF communications equipment including cellular telephones and other personal or household devices not intended for medical facilities. It is recommended that all equipment used near the Vitalograph product comply with the medical electromagnetic compatibility standard and to check before use that no interference is evident or possible. If interference is suspected or possible, switching off the offending device is the normal solution, as is required in aircraft and medical facilities.

Medical electrical equipment needs special precautions regarding EMC and needs to be installed and put into service according to the EMC information provided.

15. FDA Notice

Caution: Federal Law restricts this device to sale by, or on the order of a physician.

16. EU Declaration of Conformity

Product: Model 6000 ALPHA Touch

Vitalograph hereby ensures and declares that the above product associated with these instructions for use, is designed and manufactured in accordance with the following QMS regulations and standards:

- European Medical Devices Directive {MDD} 93/42/EEC, as amended.

This device is classified as IIa per Annex IX of the MDD also meets the provisions of the Essential Requirements, Annex I, via compliance with Annex II of the Medical Devices Directive as per Article 11, section 3a, excluding point 4 of Annex II.

- Canadian Medical Device Regulation {SOR/98-282}
- FDA Quality System Regulation {QSR} 21 CFR 820.
- EN ISO 13485 Medical devices. Quality management systems. Requirements for regulatory purposes.

Certifying Body: British Standards Institute {BSI}.

BSI Notified Body #: 2797

Certificate Nos. CE 00772, CE 85553, MD 82182.



Signed on behalf of Vitalograph (Ireland) Ltd.

A handwritten signature in black ink that reads 'Frank Keane'.

Frank Keane.

CEO, Vitalograph Ltd.

17. Guarantee

Subject to the conditions listed below, Vitalograph Ltd. and its associated companies, (hereinafter called the Company) guarantee to repair or at its opinion replace any component thereof, which, in the opinion of the Company is faulty or below standard as a result of inferior workmanship or materials.

The conditions of this Guarantee are:

1. This Guarantee shall only apply to hardware defects which are notified to the Company or to its accredited distributor within 1 year of the date of purchase of the equipment, unless otherwise agreed in writing by the Company
2. Software (meaning computer software, or user installable modules) is guaranteed for 90 days from the date of purchase.
3. The Company warrants that the software when correctly used in conjunction with the hardware will perform in the manner described in the Company's literature and user manuals. The Company undertakes to rectify at no expense to the customer any software failure notified within the period stated above, provided that the failure can be recreated and the software has been installed and used in accordance with the user manual. Notwithstanding this clause, the software is not warranted to be free of errors.
4. This Guarantee does not cover any faults caused by accident, misuse, neglect, tampering with the equipment, use of consumable items or parts not approved by the Company, or any attempt at adjustment or repair other than by personnel accredited by the Company, nor does it cover reinstatement of any configuration changes caused by the installation of any software.
5. If a defect occurs, please contact the supplier from whom it was purchased for advice. The Company does not authorise any person to create for it any other obligation or liability in connection with Vitalograph® equipment
6. This Guarantee is not transferable and no person, firm or company has any authority to vary the terms or conditions of this Guarantee.
7. To the maximum extent permitted by law, the Company does not accept liability for any consequential damages arising out of the use of, or inability to use any Vitalograph® equipment.
8. This Guarantee is offered as an additional benefit to the Consumer's statutory rights and does not affect these rights in any way.

